

Determination of Transition Metals in Complex Matrices Using Chelation Ion Chromatography

INTRODUCTION

Chelation ion chromatography facilitates the determination of low concentrations ($\mu\text{g/L}$ and lower) of transition metals in samples including seawater, brines, estuarine waters, and a variety of biological samples. These types of samples are characterized by high concentrations of alkali and alkaline earth metals that can interfere with many spectroscopic techniques for metal determinations. Chelation ion chromatography removes alkali and alkaline earth metals while concentrating the sample, then determining the analytes of interest. The principle of chelation concentration and matrix elimination is described in Dionex Technical Note 25; Determination of Transition Metals in Complex Matrices by Chelation Ion Chromatography in the summary of the Method and Discussion of the Method sections. TN 25 Table I reports that metals that can be concentrated using chelation concentration, and Table II shows a step-by-step summary of chelation ion chromatography chemistry. Here, the authors simplify the system configuration described in TN 25, using an ICS-3000 system. The separation has also been updated to include the IonPac[®] CS5A/CG5A column set. The CS5A column demonstrates improved selectivity and peak efficiency for seapartition of transition metals compared to the CS5.

In Application Note 131, a 2 mm CS5A is used for transition metal determinations at sub- $\mu\text{g/L}$ levels. The IonPac CS5A is available in 2 and 4 mm column formats; this application update supports both. The successful analysis of transition metals in a seawater sample confirms the updated chelation ion chromatography configuration reported here.

EQUIPMENT

ICS-3000 system consisting of the following modules and accessories:

DP Dual pump (Gradient/Isocratic) (P/N 061710)

TC Thermal Compartment; one 6-port valve, one 10-port valve (P/N 064651)

VWD Variable wavelength absorbance detector (P/N 064377)

Absorbance cell, 11 μL , PEEK[®] (P/N 066346)

EO eluent organizer with four 2 L bottles (P/N 062628)

AS (P/N 063120) or AS-HV (P/N 064051)

Autosampler

PC10 postcolumn pneumatic delivery system 2 mm (P/N 053591), or 4 mm (P/N 050601)

AXP pump (P/N 064507)

4 L plastic container (P/N 063292)

Chromeleon[®] 6.8 Data Management System software

CONSUMABLES

MetPac™ CC-1 concentrator column, pkg. of 2 (P/N 042156)
TMC-1 concentrator column (P/N 049000)
IonPac CG5A (4 mm) (P/N 046104) or 2 mm (P/N 052836)
IonPac CS5A (4 mm) (P/N 046100) or 2 mm (P/N 052576)
 $\frac{1}{16}$ " o.d. \times 0.010 i.d. PEEK (black) tubing (P/N 052306 for 5 feet) 10 feet (300 cm)
 $\frac{1}{16}$ " o.d. \times 0.030 i.d. PEEK (green) tubing (P/N 44777—per inch) 40 feet (1.2 m). Approximately 225 cm green tubing is required for every mL of sample loop.
Fitting, 10-32 bolt, (P/N 062980)
Fitting, ferrule, double cone, (P/N 043276)
Mixing tee, 3-way (10-32), 2, (P/N048227)

REAGENTS AND STANDARDS

Deionized water (DI), Type I reagent grade, 18.2 M Ω -cm resistivity or better.
Atomic absorption spectroscopy metal standards: iron (III), copper, nickel, zinc, cobalt, cadmium, and manganese, traceable to NIST reference materials (e.g. Sigma-Aldrich Iron Atomic Absorption Standard Solution, P/N 305952).
Nitric acid, 2.0 M, 6 \times 1L (P/N 033443) or ultrapure grade equivalent
Ammonium acetate, 2.0 M, 6 \times 1 L (P/N 033441) or ultrapure grade equivalent
Ammonium nitrate, 0.1 M, pH 3.5, 6 \times 1 L (P/N 033445)
MetPac PAR postcolumn diluents, 1 L (P/N 046094) or prepared as described in TN 25
Pryridine-2,6-dicarboxylic acid (PDCA), 20 g (P/N 039671)
(4-pyridylazo) resorcinol (PAR), monosodium monohydrate, 5 g, (P/N 039672)
Formic acid (ACS grade)
Potassium hydroxide (ACS grade)
Potassium chloride (ACS grade)

CONDITIONS

Guard Column: IonPac CG5A, 4 mm (P/N 046104) or 2 mm (P/N 052836)
Column: IonPac CS5A, 4 mm (P/N 046100) or 2 mm (P/N 052576)
Trap Column: MetPac CC-1 concentrator column (2) (P/N 042156, pkg of 2)
TMC-1 concentrator column (P/N 049000)
Eluent: 6 mM PDCA, 96 mM KOH, 94 mM formic acid and 10 mM KCl
Flow Rate: 1.2 mL/min for 4 mm or 0.30 mL/min for 2 mm
Sample Volume: 5 mL for 4 mm or 1.0 mL for 2 mm
Column Oven: 30 °C for 2 mm or 40 °C for 4 mm
Pressure: 1100–1300 psi
Detection: Absorbance: 520 nm, after postcolumn derivatization with PAR
Postcolumn Flow: 0.5 mL/min (4 mm) or 0.12 mL/min (2 mm)

PREPARATION OF SOLUTIONS AND REAGENTS

See Appendices A and B of Technical Note 25 for additional information on preparation of reagents and standards.

All prepared standards must be acidified to pH 1–2 to avoid formation of metal oxides. The authors strongly recommend that all reagents used be obtained from Dionex; alternately, obtain ultrapure grade reagents from other sources. Contamination can originate from the container used to store the prepared standard and this contamination can increase with storage. Common contaminants such as Fe (III) and Zn should be maintained at sub- μ g/L concentrations. The MetPac CC-1 is used to maintain an adequate blank from the ammonium acetate. This column must be regenerated periodically using 20 mL of 2.0 M nitric acid.

PREPARATION OF PDCA ELUENT

Add 5.4 g of KOH to 200 mL DI water in a 1 L volumetric flask. Add 1.0 g PDCA while stirring until completely dissolved. Add 5.25 mL formic acid (>99%) and 500 mL of DI water while stirring. Add 0.75 g of KCl and measure pH. Adjust the eluent pH with KOH or formic acid to 4.2. Bring to volume with DI water.

SYSTEM SETUP

Use DP pump 2 (gradient) for delivery of the chelation reagents, and the DP pump 1 (isocratic) for the analytical separation. The inline degasser is not recommended for use with this application and should be bypassed. To accomplish this, connect the eluent lines directly to the DP proportioning valve or to DP pump inlet. The AXP pump delivers ammonium acetate for matrix elimination and buffering.

1. Install columns and postcolumn reagent as described in the ICS-3000 manual.
2. Connect DP pump 2 to the 10-port valve port #10 with an appropriate length of 0.010" i.d. PEEK (black) tubing.
3. Connect port #8 and #9 with an appropriate length of 0.010" i.d. PEEK (black) tubing.
4. Install a sample loop between port #4 and #7 (5 mL for 4 mm or 1 mL for 2 mm).
5. Connect port #5 and #6 to the autosampler inlet and outlet lines respectively.
6. Connect the MetPac CC-1 column on the AXP pump outlet line. This column is used for ammonium acetate purification.
7. Connect the MetPac CC-1 column outlet to the tee with an appropriate length of 0.010" i.d. PEEK (black) tubing.
8. Connect port #3 to one of the two remaining ports of the tee with an appropriate length of 0.010" i.d. PEEK (black) tubing.
9. Connect the remaining port of the tee to the second MetPac CC-1 column inlet with an appropriate length of 0.030" i.d. PEEK (green) tubing. Place the column inside the TC compartment. Using the second tee, connect one port to 10-port valve port #1, one to the second MetPac CC-1 column outlet, and the third outlet to 6-port valve port #5 with an appropriate length of 0.030" i.d. (PEEK) (green) tubing.
10. Plug the 10-port valve port # 2 with a 10-32 end fitting. This is represented in Figure 1 by the magenta circle marked with an X.
11. Install a TCC-1 concentrator between ports #1 and #4 of the 6-port valve.

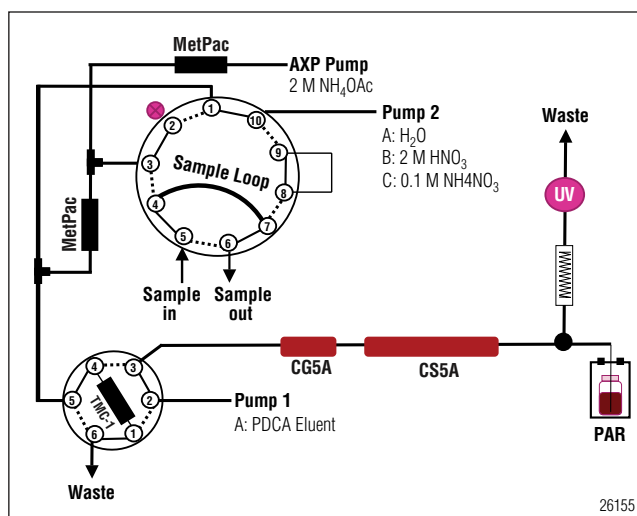

Figure 1. Chelation IC system schematic.

CHELATION IC STEPS

A total of three pumps and two valves are required to deliver the necessary reagents and change flow directions in the Chelation IC process (Figure 1). Refer to Tables 1 and 2 for the Chromeleon program steps for 5 mL (4 mm column set) and 1 mL (2 mm column set) sample loading.

1. **Sample Loading and MetPac Conditioning.** The AXP delivers ammonium acetate directly to the MetPac CC-1 at 2 mL/min. While the 10-port valve is in the A position and the 6-port is in the Inject position, the DP pump 2 flushes ports #10 and #1 with DI water at 2.0 mL/min. DP pump 1 delivers PDCA to the analytical system through the TMC-1.
2. **Chelation Concentration and Matrix Elimination.** The 10-port valve switches to B position. The DP pump 2 flushes sample from the loop with DI water. The sample stream combines with ammonium acetate and the solution flows into the MetPac CC-1 and out to waste through the 6-port valve. The AXP pump stops at the end of this step.
3. **Water Rinse.** Without valve switching, the DP pump 2 continues to flush the MetPac CC-1 with DI water to remove excess ammonium acetate.
4. **Metal Elution (Acid Elution).** The 6-port valve switches to Load position, the DP pump 2 pumps a solution of 75% water and 25% nitric acid to the MetPac CC-1 and out to the TMC-1 concentrator. Metals are removed from the MetPac CC-1 and trapped on TMC-1 concentrator.

Table 1. Valve Control Program for a 5 mL Injection Loop					
Time	DP2*	10-port	6-port	AXP*	Comments
Load	Motor on	A	Inject	OFF	Autosampler loading time
-23.0	water	A	Inject	ON	Equilibration
-22.0	water	B	—	—	Start Chelation step
-14.0	water	—	—	OFF	Start water rinse
-13.0	water	—	—	—	Stop water rinse
-12.9	25% HNO ₃	—	Load	—	Start acid elution
-5.00	25% HNO ₃	—	—	—	Stop acid elution
-4.90	NH ₄ NO ₃	A	—	—	Start TMC-1 conversion
0.00	NH ₄ NO ₃	—	Inject	—	Begin analysis
0.10	50% HNO ₃	B	—	—	MetPac CC-1 cleanup
5.00	50% HNO ₃	—	—	—	MetPac CC-1 cleanup
5.10	water	A	—	—	Water rinse
10.0	Motor off	—	—	—	End chelation steps
15.0	End program				

*DP2 and AXP flow rates: 2 mL/min.

Table 2. Valve Control Program for a 1 mL Injection Loop					
Time	DP2*	10-port	6-port	AXP*	Comments
Load	Motor on	A	Inject	OFF	Autosampler loading time
-16.0	water	A	Inject	ON	Equilibration
-15.0	water	B	—	—	Start chelation step
-11.0	water	—	—	OFF	Start water rinse
-10.0	water	—	—	—	Stop water rinse
-9.90	25% HNO ₃	—	Load	—	Start acid elution
-5.00	25% HNO ₃	—	—	—	Stop acid elution
-4.90	NH ₄ NO ₃	A	—	—	Start TMC-1 conversion
0.00	NH ₄ NO ₃	—	Inject	—	Begin analysis
0.10	50% HNO ₃	B	—	—	MetPac CC-1 cleanup
5.00	50% HNO ₃	—	—	—	MetPac CC-1 cleanup
5.10	water	A	—	—	Water rinse
10.0	Motor off	—	—	—	End chelation steps
15.0	End program				

*DP2 and AXP flow rates: 2 mL/min.

5. **TMC-1 Conversion.** The 10-port valve switches to A position and the DP pump 2 switches to ammonium nitrate. The TMC-1 in acid form converts to the ammonium form during this time. The 6-port valve switches to the Inject position at the end of this step to begin separation of metals.

RESULTS AND DISCUSSION

Chelation Concentration and Matrix Elimination

The chelation concentration and matrix elimination conditions in this application update (Tables 1 and 2) have been optimized for either 5 mL (4 mm column) or 1 mL (2 mm column) of seawater or brine. Larger volumes or samples with high concentrations of alkali and alkaline earth metals will require a larger ammonium acetate rinse volume. However, be aware that increasing the ammonium acetate rinse may affect the analytical blank. A typical blank run using the 4 mm column set is shown in Figure 2. The concentrations of Fe(III) and Zn(II) are both <1 µg/L. All data shown in this application update are with the 4 mm column set. The major benefits of using the 2 mm column set are reduction in eluent consumption and improved mass sensitivity. The latter can be significant if sample sizes are limited, which can be true for biological samples, but not typically for seawater and brine samples.

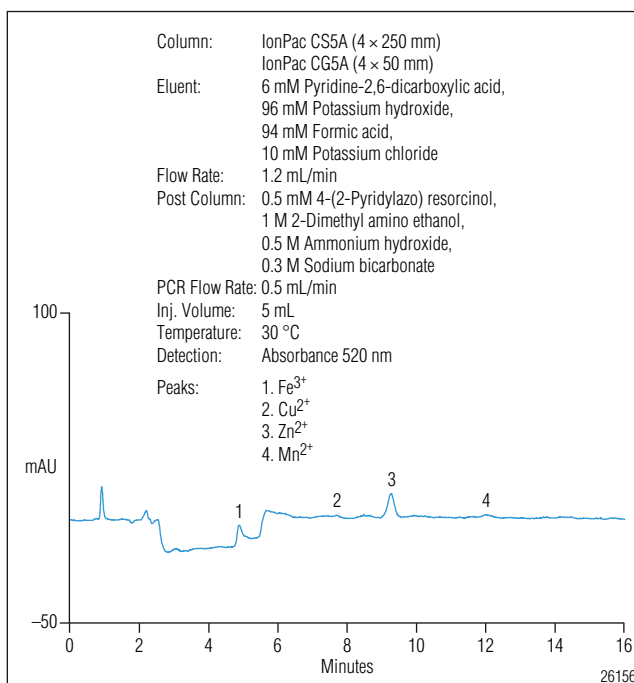

Figure 2. Typical blank chromatogram obtained from a 5 mL injection (4 mm IonPac CS5A column set).

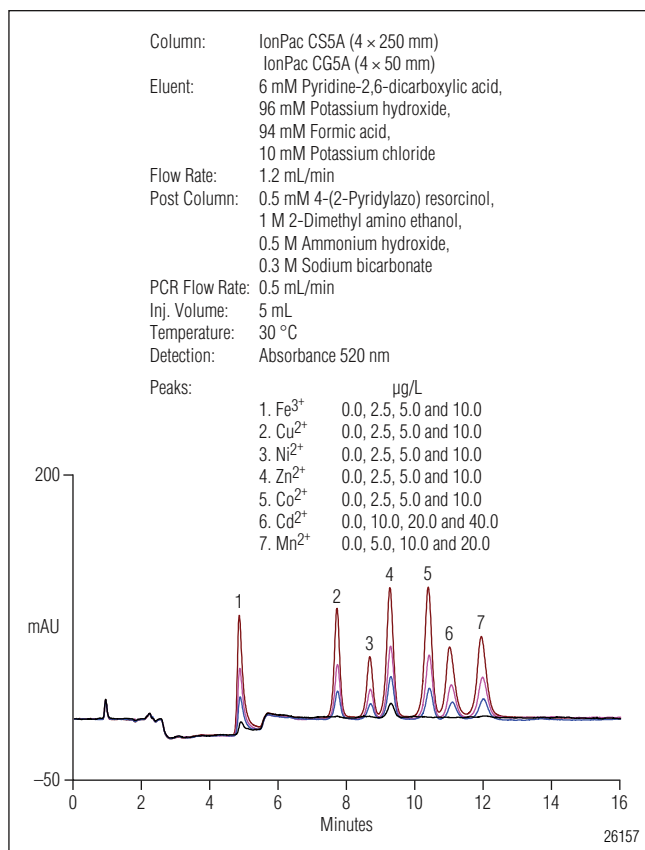

Figure 3. Overlay of chromatograms of the blanks and three standard concentrations (4 mm column set). Concentrations are shown in Table 3A.

Metal Separation

After being trapped on the MetPac CC-1 the transition metals are eluted onto the TMC-1 with nitric acid. The TMC-1 is then converted from acid to salt form. The metals elute from the TMC-1 and separated on the IonPac CS5A column set using PDCA eluent. The composition of the PDCA used in this application update differs from the standard PDCA eluent used for transition metal analysis by direct injection or after concentrating large volumes of ultrapure water as in AN 131. The PDCA eluent composition has been adjusted for higher buffering capacity to compensate for the ammonium and residual hydronium from the TMC-1. Because the authors used the same size TMC-1 with the 2 mm column set that was used with the the 4 mm column set, it is also necessary to adjust the PDCA eluent composition due to the lower capacity of the 2 mm CS5A compared to the 4 mm. This adjustment is unnecessary if the column temperature is increased from 30 °C to 40 °C.

Peak Name	Concentration (µg/L)			
	Level 1 (blank)	Level 2	Level 3	Level 4
Fe ³⁺	0.0	2.5	5.0	10.0
Cu ²⁺	0.0	2.5	5.0	10.0
Ni ²⁺	0.0	2.5	5.0	10.0
Zn ²⁺	0.0	2.5	5.0	10.0
Co ²⁺	0.0	2.5	5.0	10.0
Cd ²⁺	0.0	10.0	20.0	40.0
Mn ²⁺	0.0	5.0	10.0	20.0

Peak Name	Cal. Type	Points	R-square * 100	Offset	Slope
Fe ³⁺	LOff	4	99.8428	1.9046	1.6481
Cu ²⁺	LOff	4	99.9846	0.1225	1.6689
Ni ²⁺	LOff	4	99.8911	-0.0036	0.9831
Zn ²⁺	LOff	4	99.9977	11.6026	9.2632
Co ²⁺	LOff	4	99.9983	-0.3297	2.5727
Cd ²⁺	LOff	4	99.7806	-0.1697	0.3811
Mn ²⁺	LOff	4	99.9933	0.1281	0.9987

Calibration

Figure 3 shows an overlay of the chromatograms of the blank and three standards (Table 3A). Fe(III), Cu(II), Ni(II), Zn(II), Co(II), Cd(II), and Mn(II) are baseline resolved in under 15 min. The four-point calibration from 0 to 10 µg/L (blank included) shows that the analyte response is linear in this range (Table 3B). Note the offsets for Fe(III) and Zn(II) due to the presence of these metals in the blank. The sensitivity of this method ultimately depends on establishing a low blank. AN 131 demonstrated that this separation and detection method can achieve double-digit ng/L sensitivity, however, in that example, complex sample matrices such as seawater or brine were not analyzed. The reagents used in chelation IC—ammonium acetate, nitric acid, and ammonium nitrate—are additional sources of possible metal contamination.

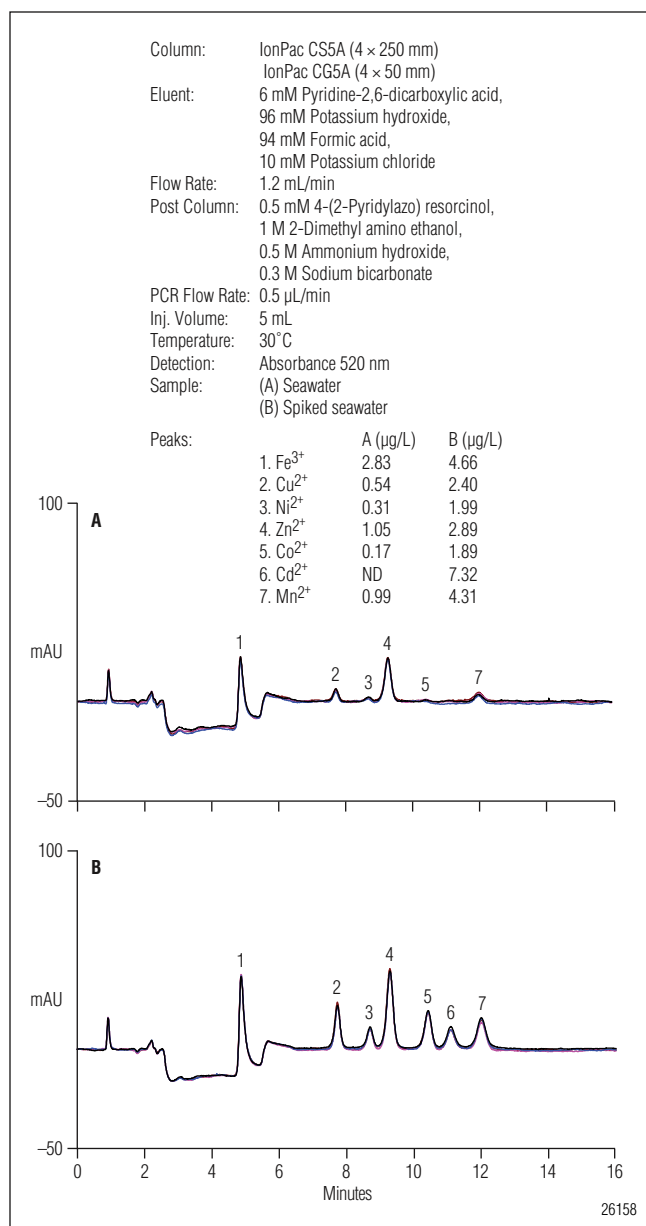

Figure 4. Analysis of seawater (A), and spiked seawater (B) using chelation ion chromatography with 5 mL loop and IonPac CS5A 4 mm column set (Overlay of 4 injections).

Sample Analysis

After calibration, the chelation IC system was used to analyze a seawater sample collected from the Gulf of Thailand for transition metals (the sample was adjusted to pH 2.0 with nitric acid upon collection.) Figure 4A shows an overlay of the chromatograms of four consecutive 5 mL seawater injections. Six of the seven metals in the standard were detected in the samples at

Table 4A. Quantification and Spike Recovery of Transition Metals in Seawater Sample

Sample Name	Sample (µg/L)	Spike (µg/L)	Sample + Spike (µg/L)		Calculated % Recovery
			Found	Expected	
Fe ³⁺	2.83	2	4.66	4.83	96.50
Cu ²⁺	0.54	2	2.40	2.54	94.63
Ni ²⁺	0.31	2	1.99	2.31	85.84
Zn ²⁺	1.05	2	2.89	3.05	94.75
Co ²⁺	0.17	2	1.89	2.17	87.29
Cd ²⁺	ND	8	7.32	8.00	91.48
Mn ²⁺	0.99	4	4.31	4.99	86.45

Table 4B. Method Precision Using 5 mL Spiked Seawater Injections and 4 mm IonPac CS5A Column

Sample #	Amount (µg/L)						
	Fe ³⁺	Cu ²⁺	Ni ²⁺	Zn ²⁺	Co ²⁺	Cd ²⁺	Mn ²⁺
1	4.55	2.34	1.98	2.85	1.89	7.95	4.57
2	4.68	2.27	1.89	2.82	1.89	6.76	4.37
3	4.70	2.40	2.15	2.88	1.87	7.60	3.77
4	4.73	2.60	1.92	3.01	1.90	6.97	4.53
Average	4.66	2.40	1.99	2.89	1.89	7.32	4.31
RSD	1.71	5.87	5.95	2.97	0.60	7.49	8.54

concentrations < 3 µg/L. The concentrations detected are shown in the second column of Table 4A. To evaluate the accuracy of the method the authors spiked the samples with 2 µg/L of each of five metals, 8 µg/L Cd(II), and 4 µg/L Mn(II). Chromatography of four consecutive injections of the spiked samples is shown in Figure 4B and Table 4A. Table 4B shows good method precision, with all metals recovered at >85%.

SUMMARY

This application update describes the setup of Chelation IC on the ICS-3000 system and provides methods for determination of transition metals analysis in seawater and brine samples. By effectively removing the high background interference, chelation IC facilitates the determination of low concentrations of transition metals in high-ionic strength samples.

1. Dionex Corporation, *Determination of Transition Metals in Complex Matrices by Chelation Ion Chromatography*, Technical Note 25, LPN 034365, Sunnyvale CA, 1990.

2. Dionex Corporation, *Determination of Transition Metals in High-Purity Water and SC2 (D-clean) Baths*, Application Note 131, LPN 1058, Sunnyvale CA, 1998.

MetPac is a trademark, and IonPac and Chromeleon are registered trademarks of Dionex Corporation.
PEEK is a trademark of Victrex PLC.

Passion. Power. Productivity.



Dionex Corporation

1228 Titan Way
P.O. Box 3603
Sunnyvale, CA
94088-3603
(408) 737-0700

North America

U.S./Canada (847) 295-7500

South America

Brazil (55) 11 3731 5140

Europe

Austria (43) 1 616 51 25 Benelux (31) 20 683 9768 (32) 3 353 4294
Denmark (45) 36 36 90 90 France (33) 1 39 30 01 10 Germany (49) 6126 991 0
Ireland (353) 1 644 0064 Italy (39) 02 51 62 1267 Sweden (46) 8 473 3380
Switzerland (41) 62 205 9966 United Kingdom (44) 1276 691722

Asia Pacific

Australia (61) 2 9420 5233 China (852) 2428 3282 India (91) 22 2764 2735
Japan (81) 6 6885 1213 Korea (82) 2 2653 2580 Singapore (65) 6289 1190
Taiwan (886) 2 8751 6655

www.dionex.com



LPN 2093 PDF 7/09
©2009 Dionex Corporation