

ELUGEN CARTRIDGE (EGC) NaOH & LiOH QUICKSTART

READ THIS FIRST

1. INSTALLATION

1.1 Plumbing (Figure 1)

- Remove the EGC from the box (NaOH, P/N 058908 or LiOH, P/N 058906).
- Save the box and foam for future storage.
- Place the EGC on a flat surface in front of the Eluent Generator (EG) with the Electrolysis Chamber and EGC INLET and OUTLET fittings facing up.
- Locate the black tubing assembly included with the EGC.
- Connect the PUMP OUT side of the black tubing assembly to the pump.
- Connect the other end, labeled "EGC-IN" to the INLET port of the EGC.
- Attach backpressure restrictor tubing (P/N 053765), supplied with the EG ship kit, to the EGC OUTLET port. This tubing will produce 2000 psi at a flow rate of 1 mL/min.
- Divert the free end of the backpressure restrictor tubing to waste.

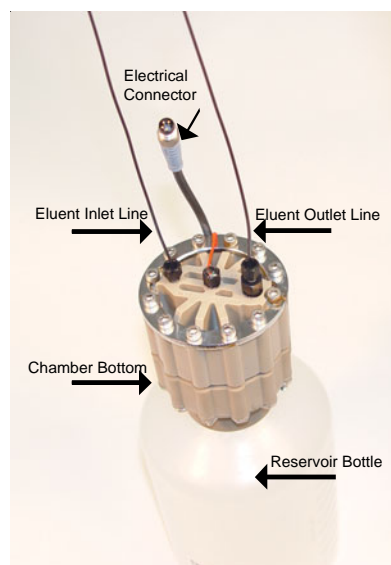

Figure 1
Bottom of EGC

1.2 Preparation (Figure 2)

- Invert the EGC with the EG Chamber downward.
- Shake the EGC vigorously.
- Tap the EG chamber with the palm of your hand 10 to 15 times.
- Watch to ensure all bubbles trapped in the EG chamber are dislodged.

NOTE: Be sure to repeat this process each time the EGC Chamber is turned upward.

- Position the EGC in the EG Module with the EG chamber downward by positioning the EGC chamber just below the shelf and the reservoir just above the shelf.
- Slide the cartridge into the opening in the shelf.

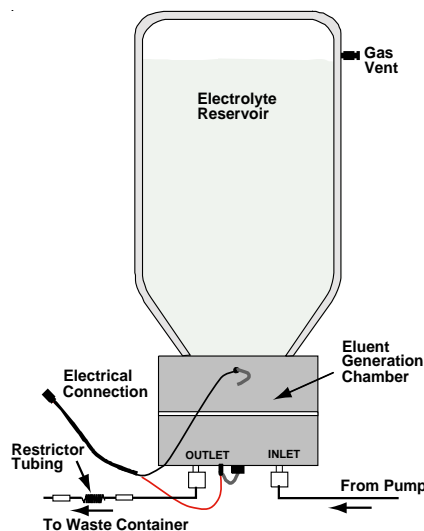

Figure 2
EGC Drawing

1.3 Conditioning

- Connect the EGC electrical connector to the "EGC Device Power" connection in the back of the EG.
- Turn On the pump from the pump front panel, PeakNet, or Chromeleon.
- Set the flow rate to 1 mL/min.

2. Continuously Regenerating Trap Column (CR-TC)

NOTE: For anion exchange applications use CR-TC, P/N 060477.
For cation exchange applications use CR-TC, P/N 060478.

2.1 Installation before Hydration (Figure 3)

NOTE 1: Do not loosen or remove the fittings with the electrical connections (fittings with wires attached).

NOTE 2: When making final plumbing connections all fittings should be finger tight plus 1/4 turn.

- Turn off power to the pump, EGC, CR-TC, and the suppressor (SRS/AES).
- Disconnect the following:
 - Trap columns (ATC or CTC) installed between the EG and the Degas Assembly.
 - Trap columns (ATC or CTC) installed between the pump and the EG module.
- Remove the plugs on the CR-TC ports before installation.
- Tightened all fittings.
- Find the tubing with the red label on one end and a white label on the other end (supplied with the EGC).
- Connect the end with the white label to the Eluent Out port of the EGC.
- Connect the end with the red label to the Eluent In port of the CR-TC.
- Connect the tubing with the orange label to the Regen In port of the CR-TC.
- Connect the tubing with the blue label to the blue Regen Out port of the CR-TC.
- Connect the tubing with the yellow label to the yellow Eluent Out port of the CR-TC.

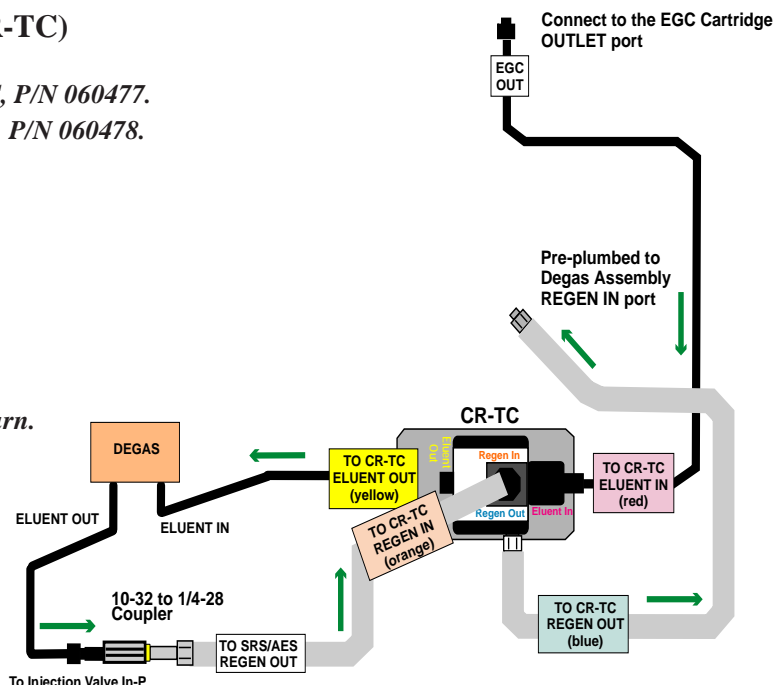

Figure 3
CR-TC Plumbing Diagram for Hydration

2.2 Hydration (Figure 3)

NOTE: The CR-TC should be hydrated after first installation before operation, or after long-term storage. This process ensures the CR-TC resin and membranes are fully hydrated and ready for operation.

- Disconnect the ELUENT OUT line protruding from the Degas Assembly at the end labeled TO INJECTION VALVE IN-P.
- Connect this end to a 10-32 to 1/4-28 coupler (P/N 042806).
- Connect the free end of the tubing, labeled TO SRS/AES REGEN OUT, to the 1/4-28 end of the coupler.
- Ensure that the current to the EGC cartridge and suppressor are turned off.
- From the pump front panel, turn on the pump flow rate to hydrate the CR-TC by pumping DI water at the flow rate of your 4-mm, 3-mm or 2-mm application for at least 10 minutes.
- Disconnect the coupler and complete the CR-TC installation by following the steps in Section 3.

3. CR-TC PLUMBING

3.1 Completing the CR-TC Plumbing for Operation (Figure 4)

- Verify the tubing labeled “TO INJECTION VALVE IN-P” is connected to the injection valve.
- Verify that the tubing with the Red label (TO CR-TC ELUENT IN) is connected to the Eluent In port of the CR-TC.
- Verify that the other end of this tubing with the White label (EGC OUT) is connected to the OUTLET port of the EGC.
- Verify that the tubing with the Yellow label (TO CR-TC ELUENT OUT) is connected to the CR-TC Eluent Out port.
- Verify that the tubing with the Orange label (TO CR-TC REGEN-IN) is connected to the CR-TC Regen In port.
- Connect the other end of this tubing with the White label (TO SRS/AES, REGEN OUT) to the suppressor REGEN OUT port.
- Verify that the tubing with the Blue label (TO CR-TC REGEN-OUT) is connected to the CR-TC Regen Out port.
- Mount the CR-TC.

NOTE: The CR-TC is mounted onto the mounting plate by aligning the hole on the CR-TC back plate with the ball stud on the mounting plate and pushing the CR-TC firmly onto the mounting ball stud. The CR-TC will click into place when properly installed.

4. CR-TC PLUMBING SCHEMATIC FOR EG

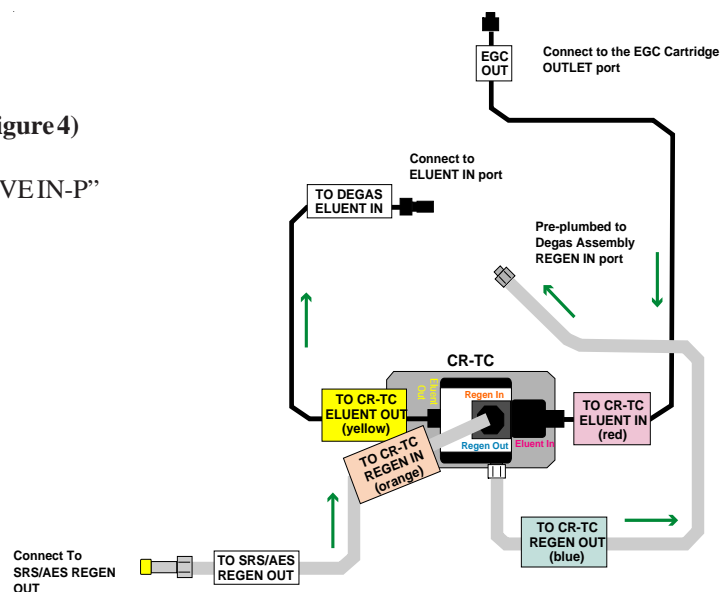

Figure 4
CR-TC Plumbing Diagram for Installation and Equilibration

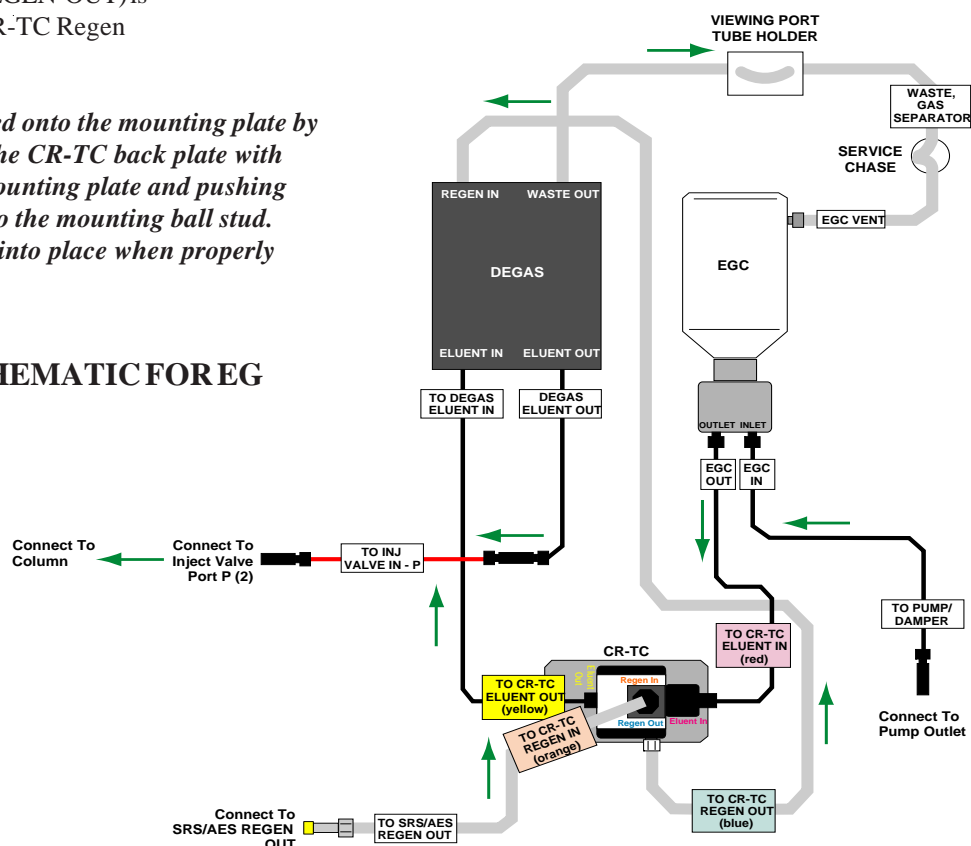

Figure 5
Plumbing Schematic for the EG with CR-TC