

Comprehensive 2-D Nano LC/MS for Human Tissue Proteomics

INTRODUCTION

The proteome of most cells, tissues, or biological fluids is a very complex mixture consisting of several thousand proteins that are distinguished by a wide range in molecular size, relative abundance, acidity, basicity, and hydrophobicity—to name just a few of their physico-chemical characteristics.

State-of-the-art mass spectrometry (MS) provides a very powerful analytical tool for the identification and characterization of complex proteinaceous samples, depending on the ability to separate efficiently the constituents prior to MS detection.

For protein and peptide separation, many separation techniques have been used, including different electrophoretic and chromatographic methods, both on-line and off-line with MS detection. Recently the use of two-dimensional (2-D) nano LC has been introduced as a complementary or alternative separation technique to 2-D gels. This approach is usually based on the injection of the digested protein sample onto a strong cation-exchange (SCX) column as a first-dimension separation. Peptides are eluted and separated from the column as fractions by injecting salt plugs of increasing concentration. Each fraction is subsequently separated on a reversed-phase (RP) column as the second orthogonal separation dimension. Using column switching, the entire procedure is on-line and fully automated. One shortcoming, however, is the limited separation power when injecting salt plugs onto the SCX column, which results in lower chromatographic

resolution. This approach often leads to elution of high-abundant peptides over two or more fractions and substantially lower peak capacity. The elution of these peptides is problematic because they will be detected and measured repeatedly in multiple fractions, which results in a significant increase in redundant MS data. In addition, the distribution of high-abundant peptides over several fractions severely hampers the identification of low-abundant proteins.

To overcome this challenge, LC Packings/Dionex has developed the UltiMate™ Plus Dual-Gradient Nano and Capillary LC System (P/N 163645). This system allows for the delivery of two independent gradients down to 50 nL/min and thereby makes the injections of salt plugs obsolete by applying a linear salt gradient in the first dimension and an acetonitrile/water/formic acid gradient in the second dimension.

In this application note, we compare 2-D nano LC with salt plugs to comprehensive 2-D nano LC, highlighting the advantages and limitations of each technique.

EXPERIMENTAL

Sample

Human tissue sample containing ~20 µg/mL protein was reduced and alkylated with dithioerythritol and iodoacetamide. The sample was digested using trypsin (Promega) for 24 h at 37 °C. Digested sample was diluted with 0.05% TFA to stop the reaction and kept at –20 °C until the analysis was performed.

INSTRUMENTATION

The UltiMate™ Plus Dual-Gradient pumping system used in this application consisted of a capillary LC pump for the first dimension separation, and a nano LC pump for the second dimension separation. Both pumps are capable of delivering a ternary gradient and are equipped with automated flow calibration, using nano and capillary flow sensors. The sensors provide precise flow rate measurement and are characterized by high precision, digital intelligence, and excellent reliability. This proprietary technology is noninvasive and totally media isolated.

A FAMOS Micro Autosampler for sample injection (P/N 163655), a Switchos (P/N 163662) for column switching equipped with two micro 10-port valves, and a loading pump were used to facilitate on-line 2-D chromatography (LC Packings/Dionex). Figure 1 shows a picture of the UltiMate Plus Dual-Gradient Nano and Capillary LC system for 2-D nano LC/MS. Figure 2 shows the schematics of the fluidic setup. For detection an esquire3000+ Ion Trap MS (Bruker Daltonics), operating in positive electrospray mode was used. The MS/MS experiments were performed using a data-dependent scanning mode with two precursor ions. A continuous capillary gradient at 6 $\mu\text{L}/\text{min}$ was used over the SCX column and two reversed-phase (RP) trap columns were used for parallel trapping of the eluting peptides prior to the separation on the nano RP column at 300 nL/min.



Figure 1. UltiMate Plus Dual-Gradient System, consisting of (left to right): FAMOS Micro Autosampler, Switchos Column-Switching Module, and UltiMate Dual-Gradient Pumping Module.

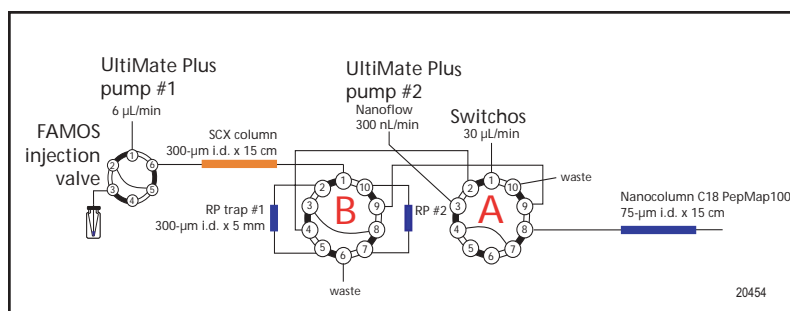

Figure 2. Schematics of 2-D nano and capillary LC setup with SCX column (1-D separation), two RP trapping columns and reversed-phase nanocolumn (2-D separation).

Other Conditions

- Sample amount: 20 μL of tryptic digested human tissue
- SCX column: 300- μm i.d. \times 15 cm, packed with POROS 10S (P/N 162122)
- RP columns: 75- μm i.d. \times 15 cm, packed with C18 PepMap100, 3 μm , 100 \AA (P/N 160321)
- Trap columns: 300- μm i.d. \times 5 mm, packed with C18 PepMap100, 5 μm , 100 \AA (P/N 160454)

Mobile Phase

SCX gradient

- 5% B increase for each fraction in 65 min, starting with 0% B in neutral wash fraction
- (A) 5 mM KH_2PO_4 , 5% acetonitrile, pH = 3
- (B) 5 mM KH_2PO_4 , 5% acetonitrile, pH = 3 + 500 mM KCl

RP gradient

- 0–60% B in 50 min
- (A) H_2O :acetonitrile (98:2), 0.1% formic acid
- (B) H_2O :acetonitrile (20:80), 0.1% formic acid

RESULTS

Figure 3 shows the UV trace at 214 nm of a direct injection of human tissue tryptic digest separated on a 75- μm i.d. \times 150-mm nano LC column. The huge surface under the peaks clearly illustrates the complexity of this sample and the limitation of 1-D nano liquid chromatography for the separation of this tryptic digest of medium complexity consisting of several hundred peptides. Figure 4 shows the corresponding base peak chromatogram (BPC).

From the MS/MS analysis and the Mascot™ data base search of the direct injection, a total of only 27 proteins could be identified with sequence coverage of 14% and Mascot score of 151 for the best match—beta tropomyosin. The expected number of proteins in this tissue is \sim 120.

Figure 5 shows the base peak chromatogram (BPC) for the 2-D nano LC/MS using salts plugs from 0 to 100 mM KCl for the elution from the SCX. A total of 7 fractions has been generated by injecting the appropriate salt plugs, including the neutral wash. The BPC reveals that most of the peptides are eluting in the neutral wash and the first two salt plugs (5 and 10 mM KCl).

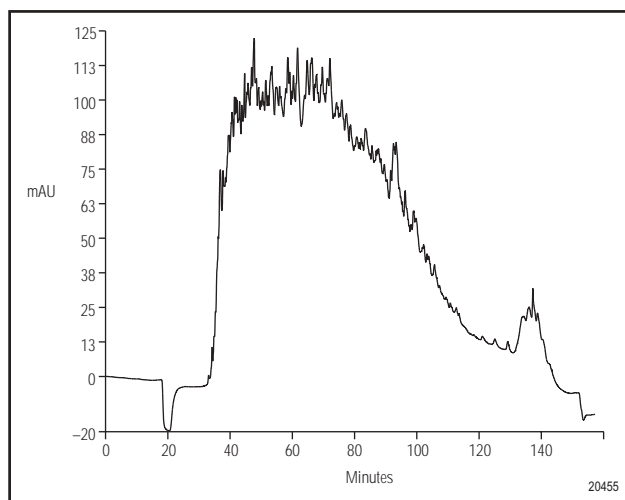

Figure 3. UV trace of human tissue tryptic peptides separated on a 75- μm i.d. \times 150 mm C18 PepMap 100, 3 μm , 100 Å, LC nanocolumn, flow rate 300 nL/min.

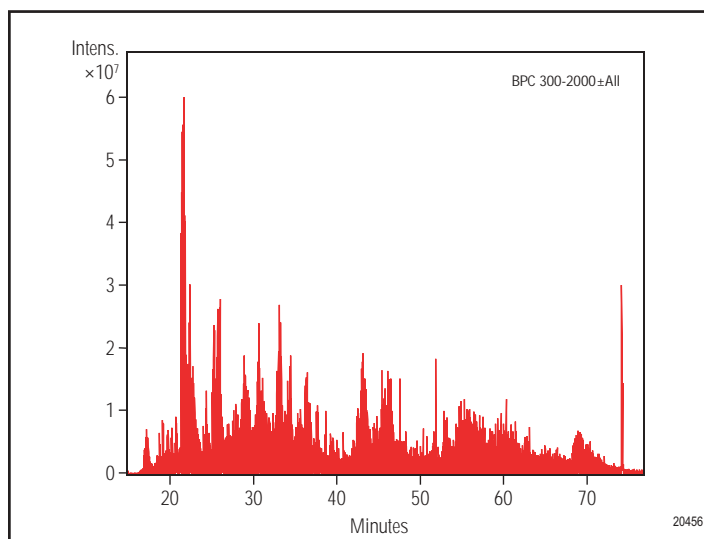

Figure 4. BPC of human tissue tryptic peptides separated by SCX, mass range 300–2000 m/z.

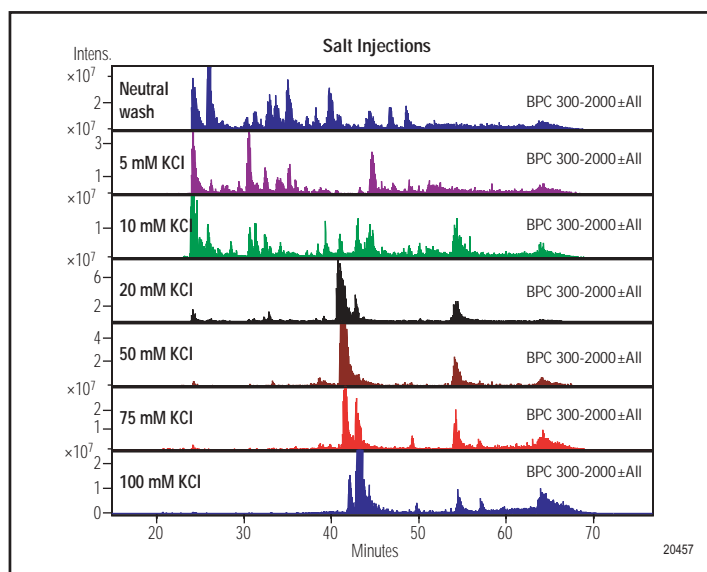

Figure 5. BPC for salt injections on SCX column, 7 fractions from 0 to 100 mM KCl, separated on a reversed-phase column.

Figure 6 shows the BPC using the comprehensive 2-D nano LC/MS with a linear salt gradient as described above. Most of the peptides eluted between 0 to 30% of 500 mM KCl. In the fraction from 30 to 50% SCX B, only 3 proteins were found (not shown). The set of BPC clearly reveals a much more homogenous elution of the peptides over different fractions using the linear salt gradient (see also Figure 9).

Figure 7 shows the MS spectrum of a randomly chosen peptide of low intensity, demonstrating the sensitivity of the method. The appropriate MS/MS is depicted in Figure 8, and the peptide could be assigned to the hemoglobin beta chain protein with a Mascot peptide ion score of 71. The total ion score of 103 for the protein and the sequence coverage of 21% were achieved.

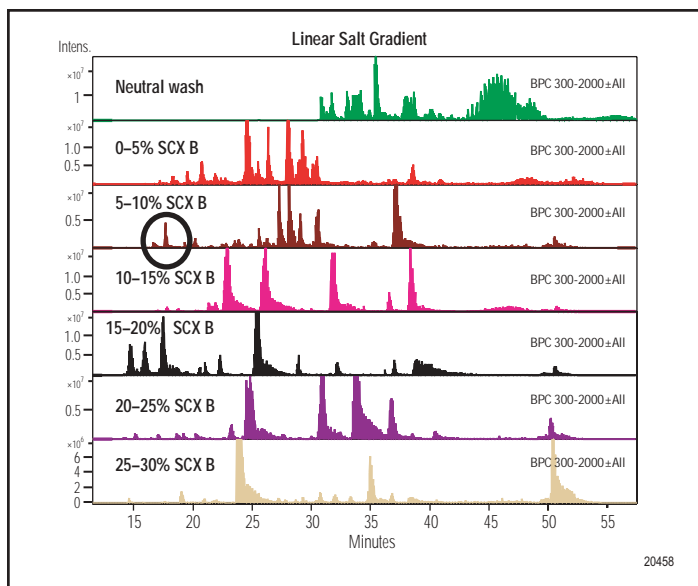

Figure 6. BPC for linear salt gradient over SCX column, 7 fractions from 0–30% 500 mM KCl shown, separated on an RP column. MS and MS/MS spectra of peak eluting at 17.9 min (highlighted by a circle) in fraction 5–10%, are shown below in Figure 7 and 8.

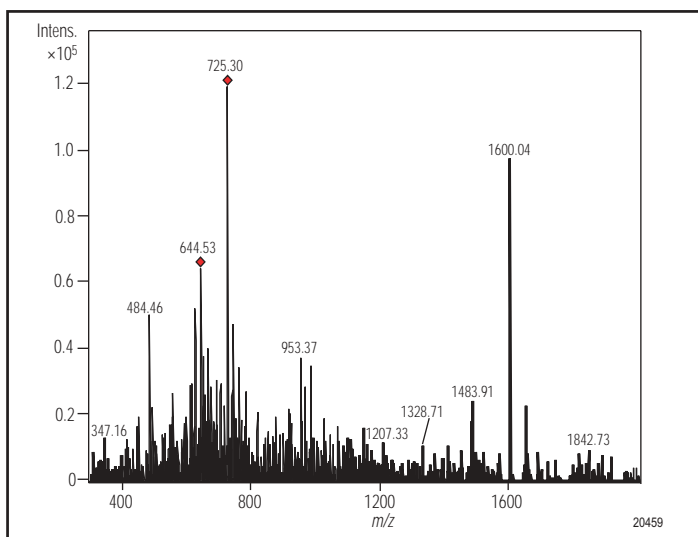

Figure 7. MS spectrum of low-intensity peptide eluting at 17.9 min, 725 m/z (MH^+)

Figure 9 shows the number of identified proteins found in each fraction using the salt steps and the linear gradient, respectively. Using the comprehensive 2-D nano LC/MS with a linear salt gradient in the 1-D separation resulted in almost twice as many protein identifications compared to the salt steps (i.e., 98 vs 53). Another advantage was the more homogenous peptide elution over the different salt fractions, unlike the approach with salt steps where more than 50% of all identified proteins were eluting in the neutral wash.

CONCLUSION

Comprehensive 2-D nano LC/MS using linear salt gradients instead of salt plugs resulted in an almost 2-times higher number of identified proteins for the given human tissue sample. The number of identified proteins is very close to the total number of proteins expected for this specific tissue sample. Another advantage observed with the comprehensive 2-D nano LC was the absence of coeluting high-abundance peptides over multiple fractions, and therefore superior chromatographic resolution.

The somewhat more complicated fluidic setup required for comprehensive 2-D LC is overcome with the commercial availability of Dual-Gradient Nano and Capillary LC Systems. The technique is currently applied for the separation of complex proteomics samples, taking full advantage of the improved separation and identification power of nano LC/MS.

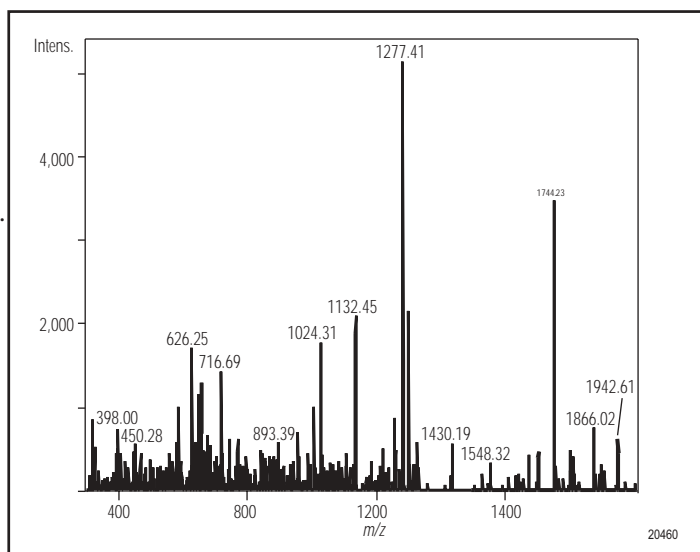

Figure 8. MS/MS spectrum of 725 m/z. Peptide identified as VVAGVANALAHKYH from gil122591 (NCBI nr) from hemoglobin beta chain with Mascot peptide ion score 71. Total ion score 103; sequence coverage 21%.

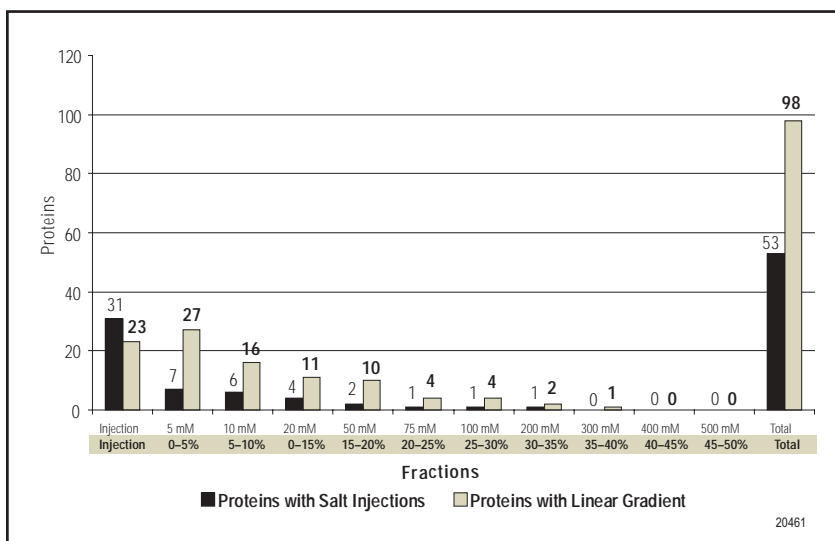

Figure 9. Number of identified proteins found in each fraction using the salt steps and the linear gradient.



Mascot is a trademark of Matrix Science, Ltd.
UltiMate and FAMOS are trademarks of Dionex Corporation.

Dionex Corporation
1228 Titan Way
P.O. Box 3603
Sunnyvale, CA
94088-3603
(408) 737-0700

Dionex Corporation
Salt Lake City Technical Center
1515 West 2200 South, Suite A
Salt Lake City, UT
84119-1484
(801) 972-9292

Dionex U.S. Regional Offices
Sunnyvale, CA (408) 737-8522
Westmont, IL (630) 789-3660
Houston, TX (281) 847-5652
Atlanta, GA (770) 432-8100
Marlton, NJ (856) 596-06009

Dionex International Subsidiaries
Australia 61 (2) 9420 5233 Austria (01) 616 51 25 Belgium (03) 353 42 94 Canada (905) 844-9650 China (852) 2428 3282
Denmark 36 36 90 90 France 01 39 30 01 10 Germany 06126-991-0 Italy (06) 66 51 50 52 Japan (06) 6885-1213
Korea 82 2 2653 2580 The Netherlands (0161) 43 43 03 Switzerland (062) 205 99 66 United Kingdom (01276) 691722
* Designed, developed, and manufactured under an NSAI registered ISO 9001 Quality System.

