

Two-Dimensional HPLC Combined with On-Line SPE for Determination of Sudan Dyes I–IV in Chili Oil

INTRODUCTION

Sudan dyes belong to a family of industrial dyes normally used for coloring plastics and other synthetic materials. Although use of these dyes in food is restricted, they are nevertheless sometimes added to foods to improve the appearance and command a higher price. Because Sudan dyes may create health problems such as genotoxic and carcinogenic effects, concerns over contamination of Sudan dyes in chili oil, powder, other spices, and baked foods have promoted increased awareness and testing for these compounds.¹ The typical adulterants are Sudan dyes I, II, III, and IV (structures shown in Figure 1).

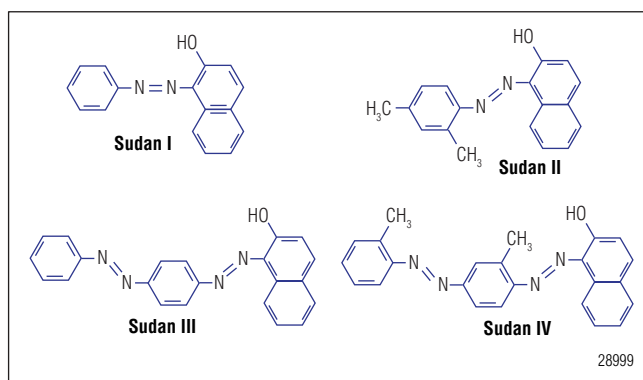

Figure 1. Structures of Sudan dyes I, II, III, and IV.

Reversed-phase high-performance liquid chromatography (RP-HPLC) is one of the preferred methods for separating Sudan dyes, and the analysis of Sudan dyes by RP-HPLC has been published by the European Union (EU) with a detection limit of 13 µg/L for Sudan dye I,² and by the Chinese government with a detection limit of 10 µg/L for Sudan dyes I–IV.³

The determination of Sudan dyes in complex matrices (e.g., chili oil) often requires extensive sample preparation prior to HPLC analysis. Due to the fat-solubility of Sudan dyes,⁴ extraction with organic solvents such as acetonitrile, methanol, n-hexane, cyclohexane, and petroleum ether is typically used. Some supplementary means (e.g., ultrasound-assisted⁵ and microwave-assisted⁶ extractions) are applied to improve the extraction efficiency. The procedure following extraction is cleanup, which is the bottleneck for the sensitive determination of Sudan dyes in chili oil. Solid-phase extraction (SPE),³ gel permeation chromatography,⁷ thin-layer chromatography,⁸ and dispersive solid-phase extraction⁹ have been reported for cleanup.

Now sold under the
Thermo Scientific brand

Thermo
SCIENTIFIC

Here, a two-dimensional HPLC with on-line SPE intercolumn trapping method was developed for fast, effective determination of Sudan dyes I–IV in chili oil. Following extraction with methylene dichloride and acetonitrile, the analytes are separated in the first dimension and removed selectively to be absorbed on an SPE column. This eliminates numerous matrix interferences. When analyte trapping is complete on the SPE column, it is switched into the flow path of the second dimension, where the absorbed dyes are eluted from the SPE column, separated, and detected. The 2-D HPLC with on-line SPE intercolumn trapping system runs automatically on the Thermo Scientific Dionex UltiMate™ 3000 HPLC dual-pump system controlled by Thermo Scientific Dionex Chromeleon™ software, and provides the advantages of full automation, absence of operator influence, and strict process control compared to a typical off-line SPE method.³

EQUIPMENT

Dionex UltiMate 3000 HPLC system including:

DGP-3600 RS Pump with SRD 3600 solvent rack with degasser

WPS-3000T RS Autosampler

TCC-3000 Thermostatted column compartment equipped with two 2p-10p valves

DAD-3000 RS UV-vis Detector

LPG-3400 Pump (for dilution)

Thermo Scientific MSQ Plus™ mass detector with electrospray ionization (ESI) source

Dionex Chromeleon software, Version 6.80, SR9 or higher

Anke® TGL-16B centrifuge, Anting Scientific Instrumental Factory, Shanghai, China

IKA® MS1 Minishaker, IKA Works, Guangzhou, China

REAGENTS

Deionized (DI) water, Milli-Q® Gradient A10, Millipore Corporation

Acetonitrile (CH₃CN) HPLC grade (Cat.# AC6100-0040) Fisher Chemical

Methanol (CH₃OH), HPLC grade, (Cat.# AC61009-0040) Fisher Chemical

Tetrahydrofuran (THF), HPLC grade, SCRC, China

Formic acid (FA), HPLC grade, SCRC, China

Methylene dichloride (CH₂Cl₂), analytical grade, SCRC, China

STANDARDS

Sudan I (CAS 842-07-9), Sudan II (CAS 3118-97-6), Sudan III (CAS 85-86-9), and Sudan IV (CAS 85-83-6) were purchased from Sigma-Aldrich.

Prepare stock standard solutions with concentrations of 3 µg/mL for Sudan I and IV, and 1 µg/mL for Sudan II and III by dissolving the appropriate amount of standards in acetonitrile. Prepare five working standard solutions ranging from 0.5 to 60 µg/L for the calibration by adding the proper amount of stock standard solution and making dilutions with water.

SAMPLE PREPARATION

The chili oil sample was donated by a customer.

Weigh 1 g of chili oil and place in a 100 mL volumetric flask, then add 20 mL CH₂Cl₂. After 5 min of vortex shaking and 30 min in an ultrasonic bath, bring to volume with acetonitrile. Return the flask to the bath for 15 min, then transfer 10 mL of the mixture to a 10 mL centrifuge tube. Centrifuge for 10 min (rpm ≥10,000), decant the acetonitrile layer, and filter through a 0.45 µm membrane (Millex-LH®) before injection.

CONDITIONS

Chromatographic Conditions

Analytical Column 1: Thermo Scientific Acclaim™ PolarAdvantage II (PA2), 3 µm, 3.0 × 150 mm (P/N 063705)

Analytical Column 2: Acclaim RSLC 120 C18 column, 2.2 µm, 2.1 × 100 mm (P/N 068982)

On-Line SPE Column: Acclaim 120 C18, 5 µm, Guard Cartridge, 4.6 × 10 mm (P/N 069580), use V-2 holder

Mobile Phase: For the separation on analytical column 1 (the first dimension)
A: DI Water
B: CH₃CN
C: CH₃OH/THF, 1:1 (v/v)
In gradient (Table 1)
For on-line SPE
0.1% FA in DI water, isocratic
For the separation on analytical column 2 (the second dimension)
A: DI Water
B: CH₃CN
C: 0.1% FA in CH₃CN
in gradient (Table 1)

Valve-Switching: Table 1
 Flow Rate: For analytical column 1
 0.6 mL/min
 For on-line SPE column
 1.0 mL/min
 For analytical column 2
 0.3 mL/min
 Inj. Volume: 20 µL on analytical column 1
 Column Temp.: 30 °C
 Detection: Absorbance at 500 nm

MSQ-Plus Mass Detector Conditions

Ionization Mode: ESI
 Operating Mode: Positive Scan
 Probe Temp.: 450 °C
 Needle Voltage: 4000 V
 SIM Mode: 249 *m/z* for Sudan dye I
 277 *m/z* for Sudan dye II
 353 *m/z* for Sudan dye III
 381 *m/z* for Sudan dye IV
 Dwell Time: 0.2 sec
 Cone Voltage: 35 V for Sudan dyes I and II
 50 V for Sudan dyes III and IV
 Nebulizer Gas: Nitrogen at 75 psi

Table 1. Gradients and Valve Switching for On-Line SPE Two-Dimensional HPLC

Time (min)	Right Pump (for the First Dimension)			Left Pump (for the Second Dimension)			Pump for Dilution (for On-Line SPE)		Valve Switching		Detector						
	Flow Rate (mL/min)	Solvent A H ₂ O (% vol.)	Solvent B CH ₃ CN (% vol.)	Solvent C CH ₃ OH/THF 1:1 v/v (% vol.)	Flow Rate (mL/min)	Solvent A H ₂ O (% vol.)	Solvent B CH ₃ CN (% vol.)	Solvent C CH ₃ CN-0.1%FA (% vol.)	Flow Rate (mL/min)	Solvent 0.1%FA in H ₂ O (% vol.)	Right	Left	UV-vis	MS			
-3.50	0.6	30	50	20	0.3	40	50	10	1.0	100%	10_1	10_1					
-0.50		30	50	20								1_2	10_1				
0.00																AcqOn	
4.72														10_1			
5.00														1_2			
5.50		0	50	50													
5.94														10_1			
6.13														1_2			
6.78														10_1			
6.96														1_2			
7.00							40	50			10						
7.53														10_1			
7.70														1_2			
8.00															1_2	AcqOff	
11.00		0	20	80													
12.00																	Start.On Duration =10.00
14.00		0	20	80													
14.10		30	50	20													
16.00								0			90	10					
22.40								0			90	10					
22.50								40			50	10					
23.00		30	50	20			40	50			10						

RESULTS AND DISCUSSION

Evaluation of Sample Preparation

The sample preparation method typically used for HPLC analysis of Sudan dyes in chili oil includes two steps: extraction and cleanup. The official EU Method 03/99 uses acetonitrile to extract Sudan dyes I and II, and CH_2Cl_2 to extract Sudan dyes III and IV from chili oil.² Experiments leading to the methods described here also demonstrate that the recoveries of Sudan dyes I and II obtained using CH_3CN as extractant were good, whereas recoveries of Sudan dyes III and IV were poor. Thus, CH_2Cl_2 and CH_3CN were used for the extraction. Vortex shaking and use of an ultrasonic bath can improve the extraction efficiency.

For the cleanup step, the Chinese GB Method recommends using activated alumina (Al_2O_3) the stationary phase to absorb Sudan dyes I–IV;³ however, the use of activated alumina may result in poor method reproducibility due to the facile reaction of alumina with Sudan dye I, which is usually used as an indicator to evaluate the alumina activity. Therefore, an efficient cleanup method with the advantages of full automation, absence of operator influence, and strict process control is required. This can be achieved using the design shown in Figure 2. The cleanup step using on-line SPE combined with a two-dimensional separation is run automatically on the Dionex UltiMate 3000 HPLC dual-pump system controlled by the Dionex Chromeleon Chromatography Data System software.

Configuration of the Two-Dimensional HPLC with On-Line SPE Intercolumn Trapping System

Figure 2 shows the flow scheme of a two-dimensional HPLC with on-line SPE intercolumn trapping system with two detectors—UV-vis and mass spectrometry (MS)—for method development and determination of Sudan dyes, respectively. This configuration requires two 2-position 10-port valves for column switching and use of the two detectors. Connect column 2 to position 9 on the left valve for the method development. With this connection, the separation of analytes on columns 1 and 2 can be observed on the UV detector.

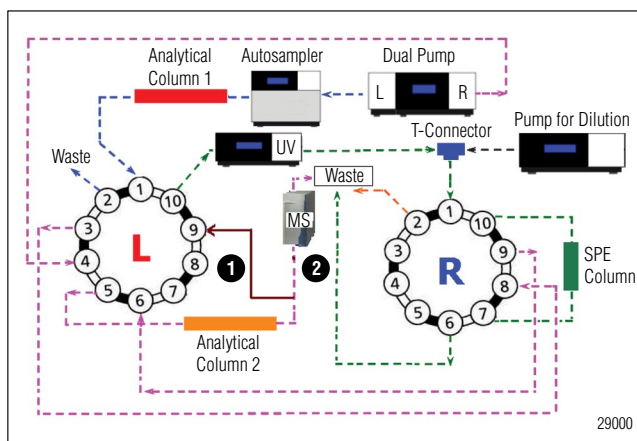

Figure 2. Flow schematics for a two-dimensional HPLC with on-line SPE intercolumn trapping system. Flow path 1 is configured for method development using a UV-vis detector; flow path 2 is configured for the determination of Sudan dyes in chili oil using an MS detector.

After method development, connect Column 2 directly to the MS detector. The two-dimensional HPLC with on-line SPE intercolumn trapping system includes an additional pump for delivering 0.1% FA into the SPE flow path through a T-connector to dilute the acetonitrile from the mobile phase in the first-dimension separation. This ensures absorption of the dyes to the SPE column. The pump runs at a constant flow rate during the entire process. While the processes of first-dimension separation (position 1-10 on left valve, and separation on analytical column 1) and on-line SPE (valve-switching between the positions 1-10 and 1-2 on right valve) are running, the second dimension (analytical column 2) is equilibrating. Before the front portion of the Sudan dye I (first analyte peak) elutes from the first analytical column, switch the SPE column into the first-dimension flow path (position 1-10 on right valve). As soon as dye I elutes from analytical column 1 and is absorbed onto the SPE column completely, switch the SPE column out of the first dimension (position 1-2 on right valve).

Removal and absorption of the other dyes follows the same protocol, so they are captured one by one on the SPE column. When the last analyte (Sudan dye IV) has been absorbed onto the SPE column completely, switch the SPE column into the second-dimension flow path (position 1-2 on both left and right valves) where the absorbed dyes are flushed from the SPE column, separated on analytical column 2, and detected with the MS detector. For method development, use a UV-vis detector connected to column 1 to determine valve-switching times. See Reference 10 for details.

Evaluation of the Two-Dimensional HPLC with On-Line SPE Intercolumn Trapping System

There are many applications of two-dimensional HPLC in the field of proteomics based on its high peak capacity for complex samples. Thermo Scientific Dionex dual-pump technology has many applications in this field.¹² A two-dimensional separation combined with on-line SPE between the two dimensions allows this technique to be applied to samples outside of proteomics. The key for this combination to be successful is to keep the on-line SPE trap working efficiently. Because the organic solvents (CH₃CN and CH₃OH) in the mobile phase from the first dimension make absorbing the Sudan dyes to the SPE column (Acclaim 120 C18) difficult, an additional pump is used to dilute the acetonitrile in the mobile phase from the first dimension with acidic aqueous (0.1% FA) (Figure 2). Use of 0.1% FA matches the mobile phase used in the second dimension, to which 0.1% FA is added as a component. Experiments show that using a dilution flow rate of either 1.0 or 1.2 mL/min yields satisfactory recovery of Sudan dyes spiked in the chili oil sample. Here, a 1.0 mL/min dilution flow rate was used.

A larger Acclaim PA2 column was used in the first dimension due to its ability to handle a large sample injection, and better selectivity for matrix removal. A smaller Acclaim 120 C18 column was used in the second dimension to obtain improved detection sensitivity and good resolution of Sudan dyes I–IV.^{13,14} For the SPE column, an Acclaim 120 C18 Guard Cartridge was used, on which Sudan dyes I–IV are easily retained using an acidic aqueous solution, and easily eluted using organic solvent.

Addition of THF to the mobile phase can compress the natural pigments in capsicum products into a sharp band with retention longer than Sudan dyes I–IV;¹⁵ for this reason, the authors suggest using THF for the first dimension separation.

Figure 3 shows chromatograms of Sudan dyes I–IV standards and the same standards spiked into chili oil samples with UV-vis detection under the chromatographic conditions specified above. The second half of the chromatogram (representing the second-dimension separation) shows efficient elimination of interferences by the on-line SPE two-dimensional HPLC system.

Method Precision, Linearity, and Detection Limits

Method precision was estimated using UV-vis detection by making five consecutive 20 µL injections of a chili oil sample spiked with 1.0 mg/L of each Sudan dye standard. The retention time and peak area reproducibilities are summarized in Table 2 and show good precision.

Calibration linearity for MS detection of Sudan dyes I–IV was investigated by making three consecutive injections of a mixed standard prepared at five different concentrations. The external standard method was used to establish the calibration curve and to quantify these dyes in the sample. Excellent linearity was observed from 0.5 to 60 µg/L when plotting the concentration versus the peak area, and the correlation coefficient was ≥ 0.9958 for each plot. The method detection limits of each Sudan dye for MS detection calculated by using $S/N = 3$ (signal to noise) were all ≤ 0.2 µg/L.

Sample Analysis

The customer who supplied a chili oil sample that tested positive for Sudan dyes requested confirmation of the types of dyes in the sample and their contents. Figure 4 shows total ion current (TIC) chromatograms of the chili oil sample and the same sample spiked with a mixed Sudan dye standard. Sudan dyes I, II, and III were identified in the chili sample. By comparing the calculated values of molecular weights with the theoretical values—249, 277, and 353, respectively—the identity of the three dyes was confirmed. Recoveries for each dye standard in the sample ranged from 67–97%. Table 3 reports the data for quantitative sample analysis as automatically calculated by the Dionex Chromeleon software.

CONCLUSION

The work shown here describes a two-dimensional HPLC method with on-line SPE intercolumn trapping for determination of Sudan dyes I, II, III, and IV in chili oil, a complex sample. This design eliminates the need for off-line sample preparation, uses the separation power of the first column to efficiently eliminate interferences, and uses the second column to separate the analytes. The method reduces the labor required for the analysis of edible oil for Sudan dyes. The Dionex UltiMate 3000 ×2 Dual HPLC system provides an efficient platform for this method design, with detection limits exceeding the requirements of the EU and GB.

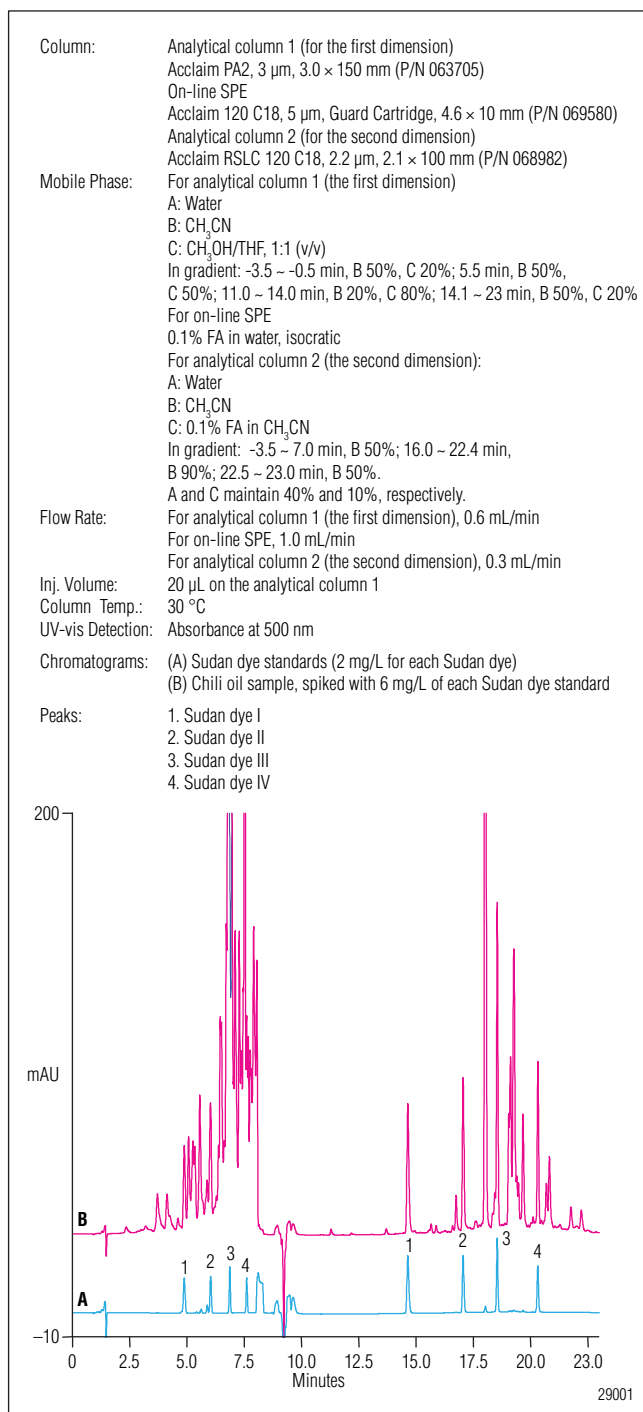

Figure 3. Chromatograms of (A) Sudan dye standards (2 mg/L for each Sudan dye), and (B) chili oil sample, spiked with 6 mg/L of each dye standard using the two-dimensional HPLC with on-line SPE intercolumn trapping system with UV-vis detection. The second dimension separation starts at 10 min.

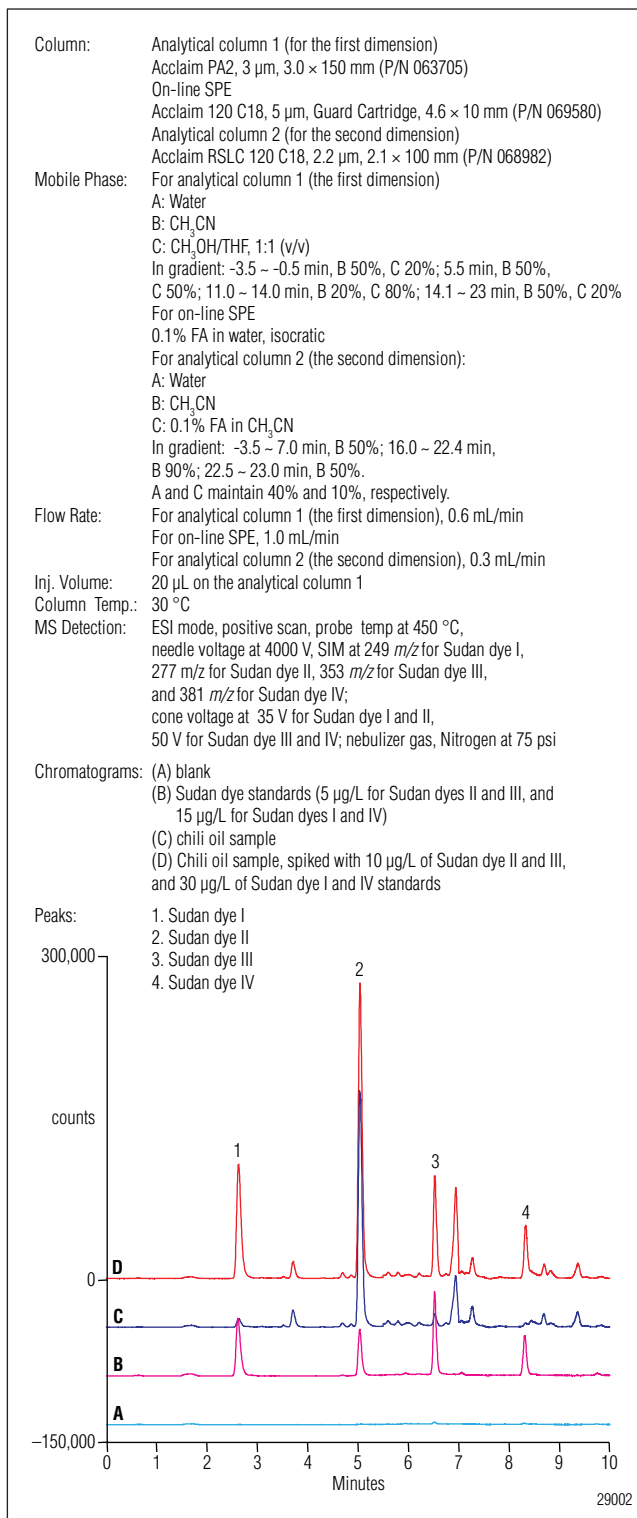

Figure 4. MS TIC chromatograms of (A) blank (CH_3CN), (B) mixed Sudan dye standards (5 $\mu\text{g}/\text{L}$ for Sudan dye II and III, and 15 $\mu\text{g}/\text{L}$ for Sudan dye I and IV), (C) chili oil sample, and (D) the same sample spiked with 10 $\mu\text{g}/\text{L}$ of Sudan dyes II and III, and 30 $\mu\text{g}/\text{L}$ of Sudan dyes I and IV using the two-dimensional HPLC with on-line SPE intercolumn trapping system with MS detection.

Sudan Dye	Retention Time RSD	Peak Area RSD	Concentration of Standard (mg/L)
I	0.090	1.211	1.0
II	0.060	0.871	1.0
III	0.052	1.350	1.0
IV	0.064	1.933	1.0

Sudan Dye	Detected (µg/L)	Added (µg/L)	Found (µg/L)	Recovery (%)
I	2.0	30	29	97
II	29	10	8.0	80
III	0.6	10	67	67
IV	ND**	30	24	80

*Average of three determinations

**Not detected

REFERENCES

1. *The Risk of Sudan Dyes in Food*, Assessment Report, No. 5; Ministry of Health of the People's Republic of China: Beijing, China, 2005.
2. Vérétoit, O.; Demesse, L.; Szymanski, L. *Analysis and Dosage of the Colorants Sudan and Bixin in Chili Powder and Pepper-Based Products*; Health & Consumer Protection Directorate-General, European Commission, NEWS notification: 03/99.
3. *The Method for the Determination of Sudan Dyes in Foods—High Performance Liquid Chromatography*, GB/T19681, China, 2005.
4. Pang, Y.L. Development in the Analysis Methods of Sudan Red in Food. *Food and Fermentation Industries (Chin.)* **2008**, *34*, 114.
5. Zacharis, C.K.; Kika, F.S.; Tzanavaras, P.D.; Rigas, P.K.; Efstratios, R. Development and Validation of a Rapid HPLC Method for the Determination of Five Banned Fat-Soluble Colorants in Spices Using a Narrow-Bore Monolithic Column. *Talanta*, In Press.
6. Ridgway, K.; Lalljie, Sam P.D.; Smith, R.M. Sample Preparation Techniques for the Determination of Trace Residues and Contaminants in Foods. *J. Chromatogr. A* **2007**, *1153*, 36.
7. Pardo, O.; Yusà, V.; León, N.; Pastor, A. Development of a Method for the Analysis of Seven Banned Azo-Dyes in Chili and Hot Chili Food Samples by Pressurised Liquid Extraction and Liquid Chromatography with Electrospray Ionization-Tandem Mass Spectrometry. *Talanta* **2009**, *78*, 178.
8. Rebane, R.; Leito, I.; Yurchenko, S.; Herodes, K. A Review of Analytical Techniques for Determination of Sudan I–IV Dyes in Food Matrixes. *J. Chromatogr. A* **2010**, *1217*, 2747.
9. Liu, H.C.; Tang, L.B.; Li, Q.W.; Liu, J.F.; Zou, Y.H. Identification of Sudan in Pepper Oil by HPLC with Two Columns and Matrix Solid Phase Dispersion. *Chin. J. Anal. Lab.* **2007**, *26* (6), 37.
10. Dionex Corporation. *Determination of Vitamin B₁₂ in Beverages Using Online Solid-Phase Extraction Followed by HPLC with UV Detection*, Application Note 256, LPN 2574, Sunnyvale, CA, 2010.
11. Dionex Corporation. *Sensitive Determination of Microcystins in Drinking and Environmental Waters*. Application Note 261, LPN 2607, Sunnyvale, CA, 2010.
12. Dionex Corporation. *Intelligent LC Solutions, UltiMate 3000 Proteomics MDLC System*. LPN 2013, Sunnyvale, CA, 2008.
13. Dionex Corporation. *Sudan Dyes on Acclaim 120 C18*. Ref. No. 23630, Sunnyvale, CA, 2009.
14. Dionex Corporation. *Oil-Soluble Dyes on Acclaim 120 C18 RSLC*. Ref No. 25641, Sunnyvale, CA, 2009.
15. Dionex Corporation. *Sudan Dyes in Paprika*. Ref No. 21787, Sunnyvale, CA, 2009.

Anke is a registered trademark of Anting Scientific Instrumental Factory.

IKA is a registered trademark of IKA Werke GmbH & Co.

Milli-Q and Milllex-LH are registered trademarks of Millipore Corporation.

All other trademarks are the property of Thermo Fisher Scientific Inc. and its subsidiaries.

Speed • Simplicity • Solutions



Dionex Products

1228 Titan Way
P.O. Box 3603
Sunnyvale, CA
94088-3603
(408) 737-0700

North America

U.S./Canada (847) 295-7500

South America

Brazil (55) 11 3731 5140

Europe

Austria (43) 1 616 51 25 Benelux (31) 20 683 9768 (32) 3 353 4294
Denmark (45) 36 36 90 90 France (33) 1 39 30 01 10 Germany (49) 6126 991 0
Ireland (353) 1 644 0064 Italy (39) 02 51 62 1267 Sweden (46) 8 473 3380
Switzerland (41) 62 205 9966 United Kingdom (44) 1276 691722

Asia Pacific

Australia (61) 2 9420 5233, China (852) 2428 3282 India (91) 22 2764 2735
Japan (81) 6 6885 1213 Korea (82) 2 2653 2580 Singapore (65) 6289 1190
Taiwan (886) 2 8751 6655

www.thermoscientific.com/dionex



LPN 2919 PDF 8/11

©2011 Thermo Fisher Scientific, Inc.