

Direct Determination of Fluoroacetate in Water by IC-MS

INTRODUCTION

Fluoroacetate (FA, compound 1080) is a strong metabolic poison commonly used as a rodenticide and preadicide.¹ Fluoroacetic acid is also an intermediate metabolite of many compounds, such as anticancer drugs 5-fluorouracil and fluoroethyl nitrosourea. Fluoroacetate is inexpensive, simple to synthesize, tasteless, and highly soluble in water. Due to the high level of toxicity when ingested,² and no known antidotes, its use has been banned or restricted in many countries. The United States Environmental Protection Agency (U.S. EPA) has placed sodium fluoroacetate in Toxicity Category I indicating the highest degree for acute oral toxicity. It is therefore crucial to develop a method for determination of fluoroacetic acid.

Analyses for fluoroacetate have been previously performed using several methods, including gas chromatography,³ HPLC,⁴ and fluoride ion selective electrode.⁵ Many of these techniques relied upon derivatization prior to analysis⁶⁻⁸ and lacked adequate sensitivity for low-level detection. Use of chromatographic separation with selected ion monitoring (SIM) mass spectrometry (MS) detection affords the opportunity to reliably identify this compound at trace levels in water samples.

This study undertook an investigation to quantify fluoroacetate without prior derivatization or sample pretreatment. An ion chromatography (IC) method was developed with an MS detector. A fortified drinking water matrix was prepared following U.S. EPA guidelines and used to challenge the separation and robustness of the method. Samples of fortified drinking water spiked with the analyte were injected directly. Monitoring the mass-to-charge ratio (m/z) in SIM mode on a single quadrupole instrument allowed for highly sensitive and selective analysis. Method performance parameters such as linearity, calibration range, precision, accuracy, and detection limits were determined.

Now sold under the
Thermo Scientific brand

Thermo
SCIENTIFIC

EXPERIMENTAL

Equipment

Dionex ICS-3000 RFIC™ system* including:

- DP Dual Pump
- EG Eluent Generator (KOH)
- CR-ATC trap cartridge
- DC Detector Compartment
- CD Conductivity Detector
- AS Autosampler

MSQ Plus™ single quadrupole mass spectrometer

AXP Auxiliary Pump

Chromeleon® 6.8, SR10 Chromatography Data System (CDS) software

*This application can also be performed using the ICS-5000 system.

CHROMATOGRAPHIC CONDITIONS

IC System

Columns: IonPac® AG24 guard column (2.1 × 50 mm)
IonPac AS24 column (2.1 × 250 mm)

Mobile Phase: Electrolytically generated KOH gradient

Gradient:	Time (min)	Conc. (mM)
	0	5
	20	5
	20.1	80
	30.1	80
	30.2	5
	37.2	5

Flow Rate: 0.25 mL/min

Temperature: 15 °C

Inj. Volume: 100 µL (full loop)

Detection: Suppressed conductivity: ASRS® 300,
2 mm, external water mode (0.5 mL/min)

MS Parameters

ESI: Negative ion

SIM Scan: -77.0 *m/z* with 0.7 *m/z* span,
dwell time 1.0 s

N₂ Pressure: 80 psi

Probe Temp.: 450 °C

Needle Voltage: 2 kV

Cone Voltage: 45 V

Plumb a divert valve after the CD detector to allow other compounds to be directed away from the MS after the elution of the analytes of interest. Add a flow of 0.1 mL/min of CH₃CN via a low-volume mixing tee prior to the MS to aid with the thermally assisted pneumatic nebulization of the electrospray ionization (ESI) source.

Divert Valve

Time (min)	Position
0	To Waste
0.1	To MS
20	To Waste

(See Figure 1.)

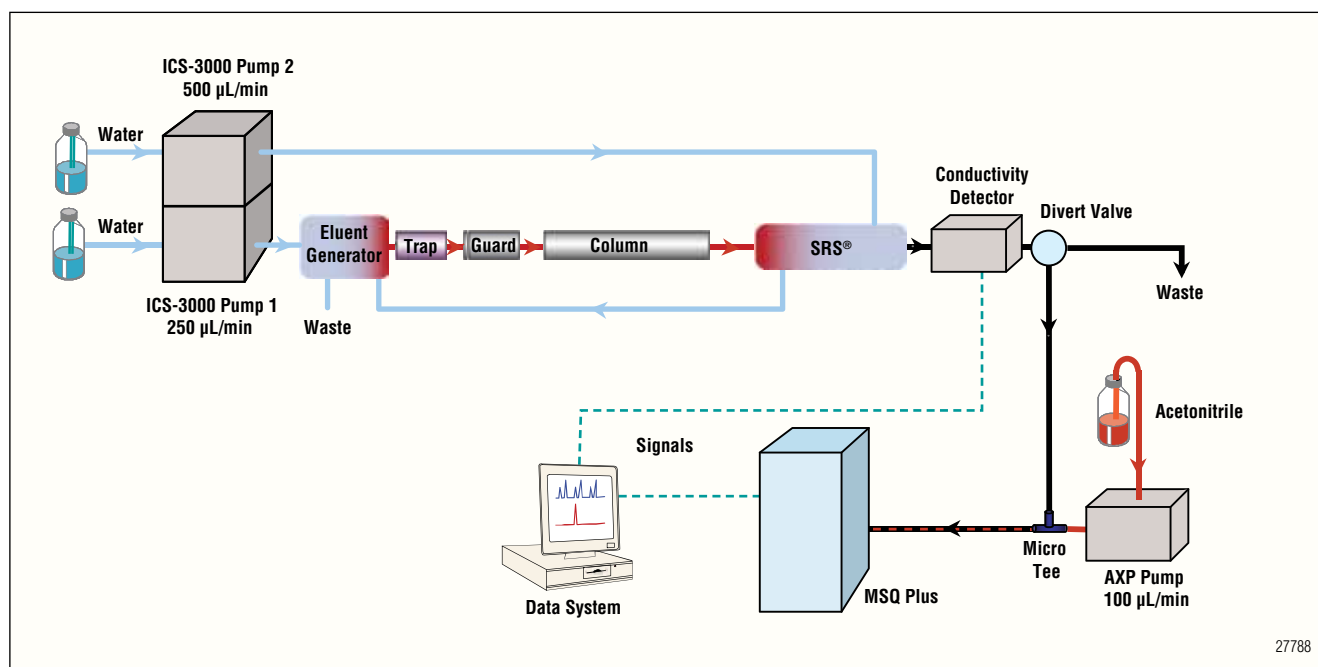

Figure 1. Schematic of an RFIC-MS system.

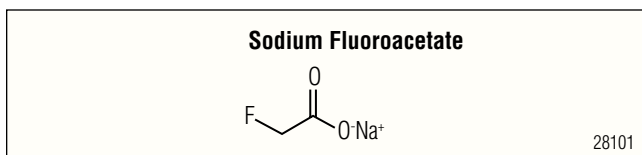

Figure 2. Structure of sodium fluoroacetate.

PREPARATION OF SOLUTIONS AND REAGENTS

Sodium fluoroacetate (CAS 62-74-8, Sigma-Aldrich P/N 36755). Figure 2 shows the chemical structure.

Acetonitrile (HPLC grade, Burdick & Jackson P/N AH015-4).

Deionized (DI) water, 18.2 MΩ-cm resistance, produced by a Millipore water station.

Salts to make a synthetic drinking water (DW), including:

- 250 mg/L sodium chloride (NaCl, CAS 7647-14-5, J.T. Baker P/N 4058-05)
- 250 mg/L sodium sulfate (Na₂SO₄, CAS 7757-82-6, EM Science P/N SX0760-1)
- 150 mg/L sodium bicarbonate (NaHCO₃, CAS 144-55-8, EM Science P/N SX0320-1)
- 30 mg/L sodium nitrate (NaNO₃, CAS 7631-99-4, Sigma-Aldrich P/N 22,134-1)

Prepare a total of 250 mL of synthetic DW using the above recipe. Prepare a primary stock solution of FA at 1000 µg/mL (ppm) in DI water. Prepare working stock solutions by diluting the primary stock solutions individually into DI and DW at 10 ppm and 100 ppb concentrations. Use these to subsequently prepare calibration standards and spiked DW samples.

CALIBRATION

Prepare FA standards in clean DI water at 12 concentrations: 0.1, 0.2, 0.5, 1, 2, 5, 10, 20, 50, 100, 200, and 500 ppb. Full loop injections of 100 µL yield a total amount of 10 pg to 50 ng loaded on column (Figure 3).

Prepare samples in fortified DW spiked at the same 12 levels as the DI standards. To obtain an estimate of the limits of detection (LOD), analyze a 2 ppb standard in DI water and a 2 ppb concentration in DW each seven times.

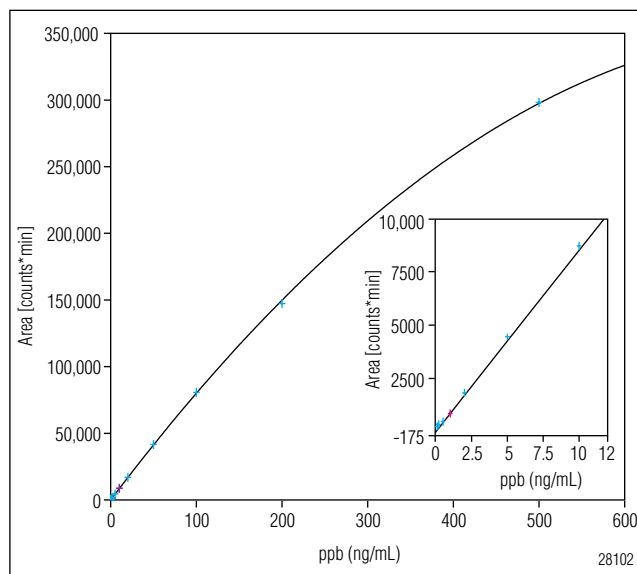

Figure 3. Calibration curve of fluoroacetate, 0.1–100 ppb in DI water.

RESULTS AND DISCUSSION

Chromatography

As shown in Figure 4, FA was retained well on the IonPac AS24 column. A retention factor (*k'*) of 8 was observed, indicating sufficient retention to separate the target from matrix interferences. The IonPac AS24 column was chosen for its high capacity, which allows large injection volumes and improves detection limits, especially in high ionic strength samples. Although the analyte eluted at ~12.5 min, the complete run was 37.2 min long. This allowed strongly retained ions to be washed off the column with a strong eluent before returning and equilibrating to starting conditions before the next sample injection. This improved method ruggedness when analyzing the fortified DW samples.

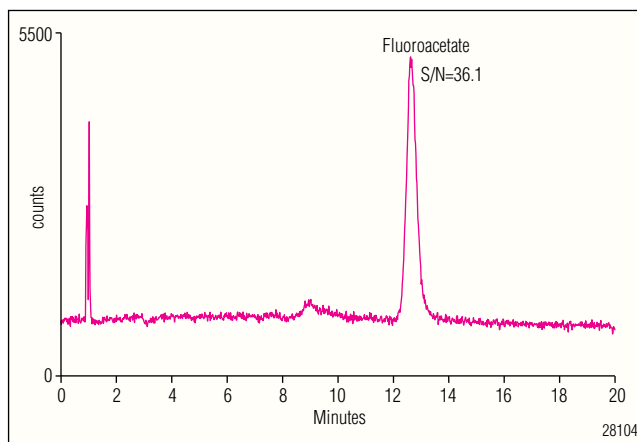

Figure 4. SIM chromatogram of -77 m/z fluoroacetate at 2 ppb in DI water.

Mass Spectrometry

The aim of the study was to develop a selective and sensitive method for direct analysis of trace levels of fluoroacetic acid in environmental water samples. The mass spectrometer provides inherent selectivity based on m/z , and operation in SIM mode provides increased sensitivity. Under IC conditions, the FA showed a strong deprotonated molecular ion at 77.0 m/z in negative ESI mode. The ionization parameters were optimized independently, starting with varying cone voltage, then needle voltage, and finally probe temperature. Optimal parameters are recorded in the Chromatographic Conditions section. The scan dwell time was optimized to give good peak shape given the chromatographic width of the peak. Longer dwell times result in greater signal accumulation and better S/N but reduce the number of points across the chromatographic peak. Narrow chromatographic peaks require shorter dwell times to maintain good peak shape. Note that optimal parameters for MS analysis are instrument- and compound-dependent, and analysts wishing to repeat these experiments are advised to evaluate all acquisition parameters to determine optimal values for different systems and analytes.

METHOD PERFORMANCE

Selectivity for FA was established through the use of a SIM scan on the molecular ion, and when combined with chromatographic retention time, ensured that the FA was being accurately identified. Carryover was evaluated by injecting sample blanks (DI water) after a 500 ppb standard injection. No detectable peak was observed at the specific retention time. A quadratic curve best fit the calibration data because high concentrations contributed to saturation effects of the MS detector. Accuracy was calculated as observed amount/specified amount $\times 100\%$. Across the range from 1 ppb to 500 ppb, accuracy was $\pm 15\%$, with most concentrations observed within 8% of expected. Recovery accuracy in DW was within 10% across concentrations from 0.5 ppb to 200 ppb (Figure 5 and Table 1). Run-to-run precision and accuracy were evaluated by seven replicate injections of a low-level standard at 2 ppb. Method detection limit (MDL) was estimated using the standard deviation obtained from the seven replicates using the following equation:

$$MDL = S \times t_{99\%, n-1=6}$$

where S is the standard deviation and t is the Student's t at 99% confidence interval. Detection limits were calculated to be 0.3 ppb for FA in DI water, and 1.8 ppb in fortified DW. This is better than reported results for GC analyses that require ethylation and solid-phase microextraction for analysis yet only achieved a 1 ppb detection limit in clean water and a 10 ppb detection limit in blood and plasma matrices. This method illustrates that good separation can be achieved with the IonPac AS24 column, and when combined with the selectivity and sensitivity of the MSQ Plus mass spectrometer, provides accurate identification and quantification.

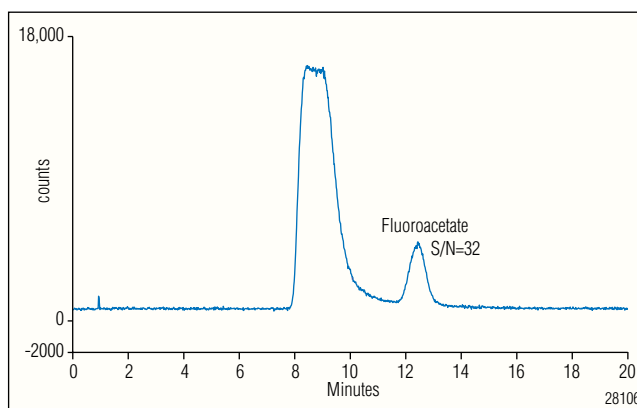

Figure 5. SIM chromatogram of -77 m/z , 2 ppb fluoroacetate in drinking water (DW).

Table 1. Fortified Drinking Water Response

Fluoroacetate Concentration (ppb)	Average (n = 3)	RSD	Recovery (%)
0.10	ND	—	—
0.20	ND	—	—
0.50	0.47	12.52	93
1.00	0.92	12.53	92
2.00	1.51	43.64	98
5.00	4.96	7.55	99
10.00	9.52	15.97	95
20.00	20.64	20.46	103
50.00	53.25	18.17	107
100.00	89.96	10.74	90
200.00	216.42*	12.25	108
500.00	395.89	6.68	79

*Average of two analyses

**n=10 (3 plus 7 LOD measurements)

CONCLUSION

Excellent recovery and detection of FA was achieved at sub-ppb concentrations using Reagent-Free Ion Chromatography (RFIC) coupled with MS detection. Matrix effects which lead to signal suppression were minimized by using a high capacity column that separated FA from matrix ions. By diverting these matrix ions to waste prior to entering the ESI source, low detection levels were achieved. The MSQ Plus spectrometer provided molecular ion analyte selectivity, and the SIM function achieved good low-level quantification.

REFERENCES

1. Kalmbach, E. R. Ten-Eighty, a War-Produced Rodenticide. *Science* **1945**, *102* (2644), 232–233.
2. Proudfoot, A.T.; Bradberry, S.M.; Vale, J.A. Sodium Fluoroacetate Poisoning. *Toxicol Rev.* **2006**, *25* (4), 213–219.
3. Koryagina, N.L.; Savelieva, E.I.; et al. Determination of Fluoroacetic Acid in Water and Biological Samples by GC-FID and GC-MS in Combination with Solid-Phase Microextraction. *Anal. Bioanal. Chem.* **2006**, *386*, (5), 1395–4000.
4. Collins, D.M.; Fawcett, J.P.; Rammell, C.G. Determination of Sodium Fluoroacetate (Compound 1080) in Poison Baits by HPLC. *Bull. Environ. Contam. Toxicol.* **1981**, *26* (5), 669–673.
5. Peters, J.A.; Baxter, K.J. Analytical Determination of Compound 1080 (Sodium Fluoroacetate) Residues in Biological Materials. *Bull. Environ. Contam. Toxicol.* **1974**, *11* (2), 177–183.
6. Mori, M.; Nakajima, H.; Seto, Y. Determination of Fluoroacetate in Aqueous Samples by Headspace Gas Chromatography. *J. Chromatogr., A* **1996**, *736*, 229–234.
7. Okuno I.; Meeker, D.L. Gas-Liquid Chromatographic Determination of Sodium Fluoroacetate (Compound 1080). *J. Assoc. Off. Anal. Chem.* **1980**, *63* (1), 49–55.
8. Allender WJ. Determination of Sodium Fluoroacetate (Compound 1080) in Biological Tissues. *J. Anal. Toxicol.* **1990**, *14* (1), 45–49.

ASRS, Chromeleon, and IonPac are registered trademarks, and RFIC is a trademark of Dionex Corporation. MSQ Plus is a trademark of Thermo Fisher Scientific, Inc.

Speed • Simplicity • Solutions



Dionex Corporation

1228 Titan Way
P.O. Box 3603
Sunnyvale, CA
94088-3603
(408) 737-0700

North America

U.S./Canada (847) 295-7500

South America

Brazil (55) 11 3731 5140

Europe

Austria (43) 1 616 51 25 Benelux (31) 20 683 9768 (32) 3 353 4294
Denmark (45) 36 36 90 90 France (33) 1 39 30 01 10 Germany (49) 6126 991 0
Ireland (353) 1 644 0064 Italy (39) 02 51 62 1267 Sweden (46) 8 473 3380
Switzerland (41) 62 205 9966 United Kingdom (44) 1276 691722

Asia Pacific

Australia (61) 2 9420 5233 China (852) 2428 3282 India (91) 22 2764 2735
Japan (81) 6 6885 1213 Korea (82) 2 2653 2580 Singapore (65) 6289 1190
Taiwan (886) 2 8751 6655

www.dionex.com



LPN 2807 PDF 5/11
©2011 Dionex Corporation